

---

# FLOW-TEK FLANGED SERIES

1 PIECE FLANGED STANDARD PORT 1" - 12"  
RF15 - ASME CLASS 150 | RF30 - ASME CLASS 300

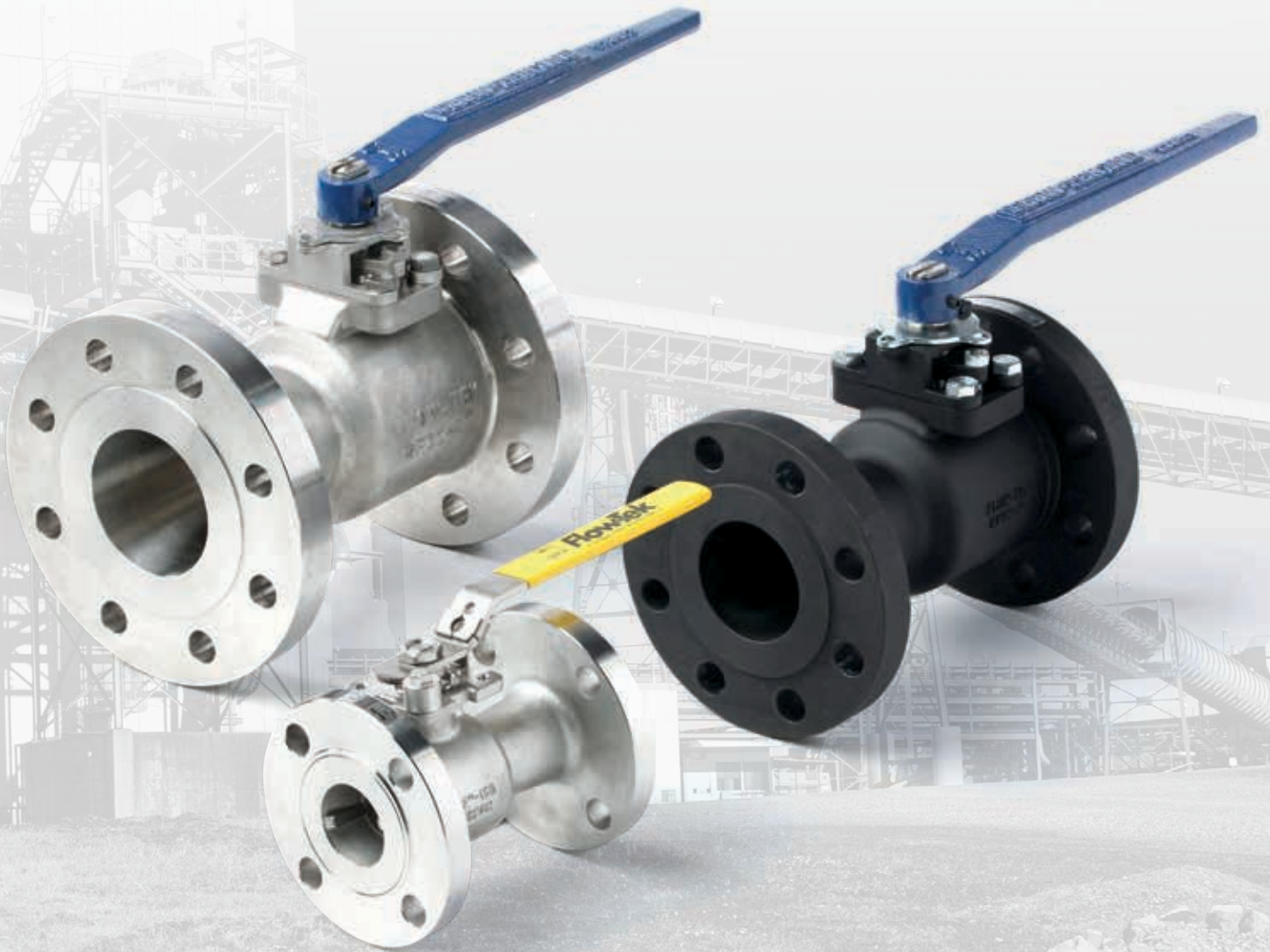

**DMC**<sup>®</sup>

DMC Gas Equipment Limited

☎ (+852) 2851 2121

✉ [dmcsaleshk@dmc-gas.com.hk](mailto:dmcsaleshk@dmc-gas.com.hk)

🌐 [www.dmc-gas.com.hk](http://www.dmc-gas.com.hk)

 **Bray**<sup>®</sup>

THE HIGH PERFORMANCE COMPANY

# RF15/RF30 FLANGED SERIES BALL VALVES

Flow-Tek's Series RF15 and RF30 Ball Valves feature a compact, one piece body design with threaded insert. The one piece body supplies maximum structural strength while minimizing the number of potential leak paths. A floating ball design offers low torque and increases valve cycle life. These rugged, economical, end entry flanged ball valves are ideal for industrial applications.

## STEM SEALS

Series RF15/RF30 1" – 2" valves feature live-loaded, self-adjusting primary and secondary sealing. Utilizing belleville washers, the stem seal automatically adjusts to compensate for changes in temperature and normal wear. 3" – 12" valves utilize an independent packing gland which can be easily adjusted without removing mounting hardware or operator. The packing gland is contoured to more uniformly distribute the load across the packing.

The primary seal is a combination of a thrust washer and thrust washer protector. An adjustable stem packing creates a secondary seal between the stem and body. The stem packing is composed of RPTFE V-rings as standard – graphite stem packing is standard on all Fire Safe valves.

## BALL

Flow-Tek balls are precision machined and mirror finished for bubble-tight shut off and less operating torque. As an added safety feature, a hole in the stem slot of each ball equalizes pressure between the body cavity and the line media flow.

## BODY

1" – 4" valve bodies are investment cast and all valve size castings are solution annealed/normalized for the highest quality and added strength. All body castings are marked with a foundry heat number for full traceability.

## SEAT

Flow-Tek's seat design ensures bi-directional, bubble-tight sealing with low operating torque. All resilient seats feature relief slots or seat O.D. clearance to relieve pressure past the upstream seat and provide positive preloading to ensure low pressure/vacuum sealing.

## ANTI-STATIC DEVICES

All RF15/RF30 valves have Anti-Static Devices as standard. These devices positively ground ball and stem.

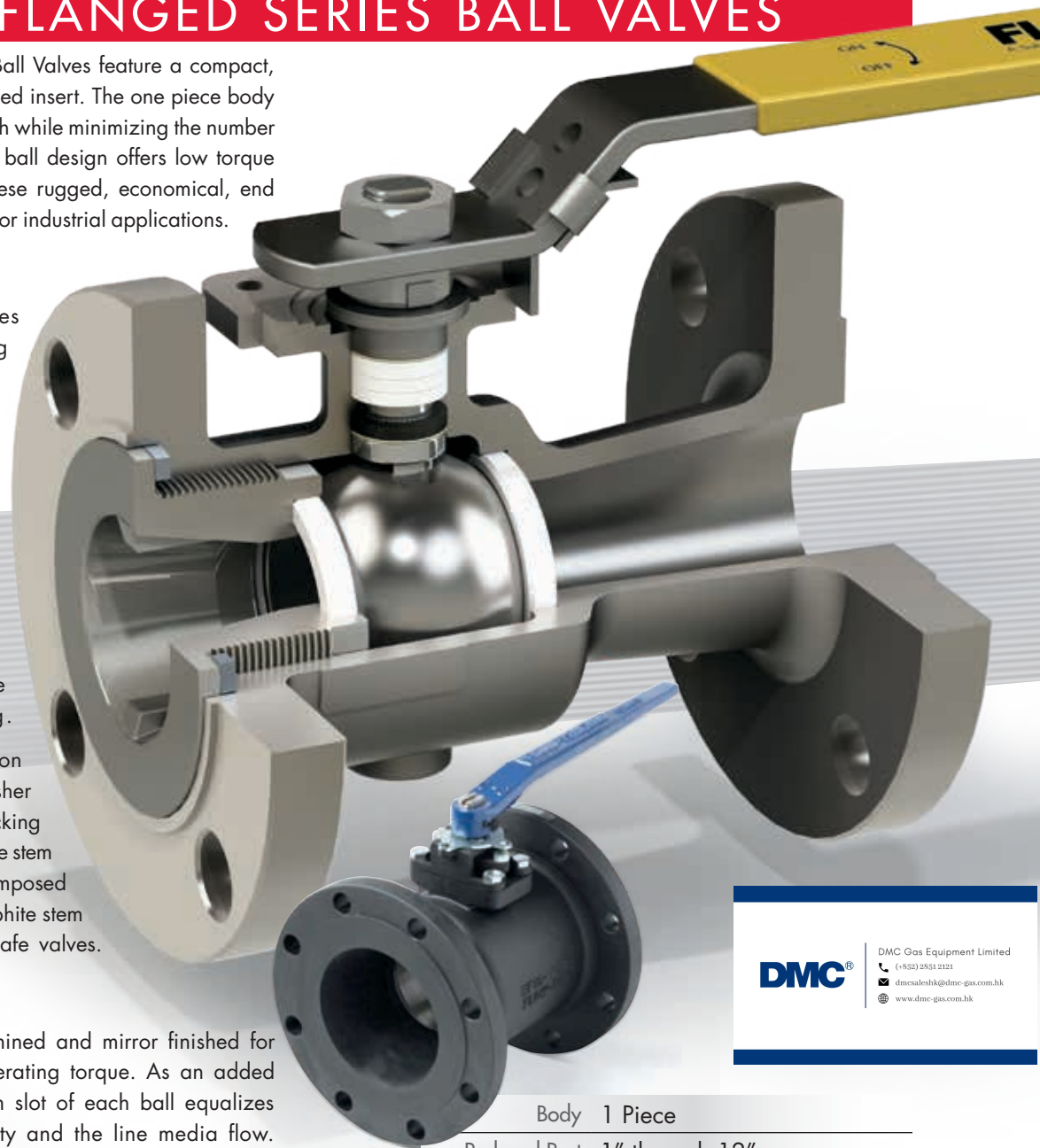

DMC Gas Equipment Limited  
(+852) 2551 2121  
dmcsaleshk@dmc-gas.com.hk  
www.dmc-gas.com.hk

Body	1 Piece
Reduced Port	1" through 12"
Materials	Stainless Steel, Carbon Steel & Special Alloys
Pressure Ratings	RF15: ASME Class 150 RF30: ASME Class 300

## LOCKING DEVICE

All manually operated valves feature a locking device to prevent accidental movement of ball position.



## SECURE MOUNT

Series RF15/RF30 valves offer ease of automation due to an integrally cast actuator mounting pad that complies with ISO 5211 through 2" valve sizes.



## STEM ASSEMBLIES

Flow-Tek manufactures heavy duty, high quality stems with double "D" connection to ball and operator mounting. Stem and ball design ensure positive contact. All Flow-Tek stems are internal entry and blowout proof for maximum safety.

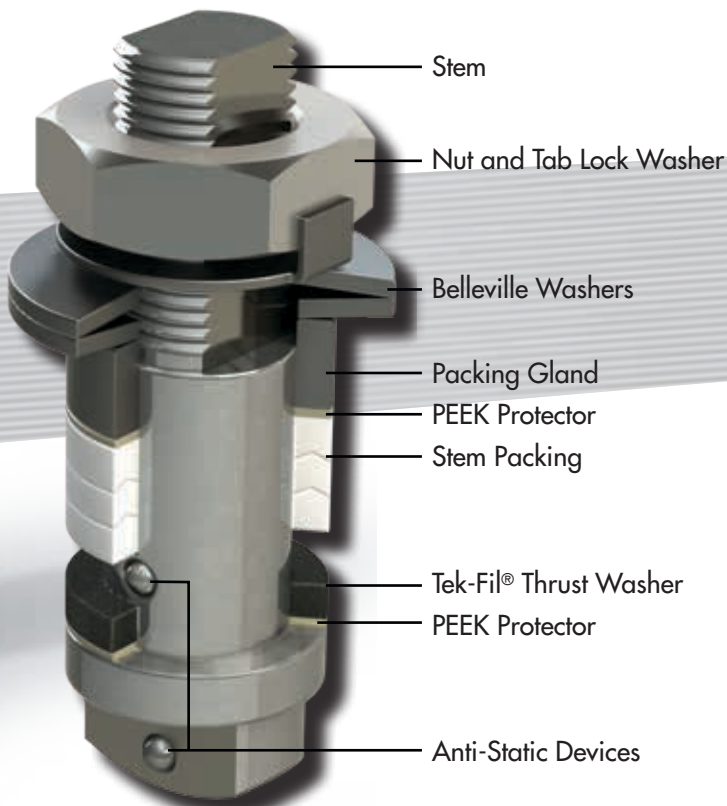

## SMART STEM Valve Sizes up to 2"

Flow-Tek's Interchangeable Family of valves feature strong, large diameter stems with live-loaded, self-adjusting sealing utilizing belleville washers which automatically adjust to compensate for changes in temperature and wear. Manual adjustments which can cause damage to the seal and seat are not required. The assembly is secured by a saddle-type lock washer which prevents stem nuts from unthreading in high cycle automation applications.

## STEM PACKING

An adjustable V-ring design creates a multiple seal between the stem and body. Each stem assembly is composed of three or four (dependent on valve size) rings providing a very high cycle life by resisting creep and cold flow. The Thrust Washer and the Thrust Washer Protector combine to provide a primary seal, reduce torque and prevent galling. This arrangement is a Flow-Tek exclusive.



## RF15/RF30 OPTIONS

- V-Control Valves
- Safety Exhaust
- Upstream or Downstream Venting
- Tri-Port Balls
- Self Draining
- Steam Jackets
- Media Containment units

additional options are available upon request

## FIRE SAFE - Certified to API 607

Flow-Tek's Series RF15/RF30 valves with graphite stem packing meet the highest fire safety standards under extreme conditions. In the event of a fire, after heat destroys the primary resilient seat, the ball makes contact with the secondary metal seat, forming a secure seal.

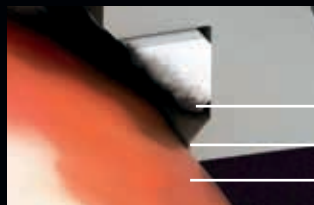

- Burned Seat
- Secondary Metal Seat
- Ball

## PRESSURE / TEMPERATURE

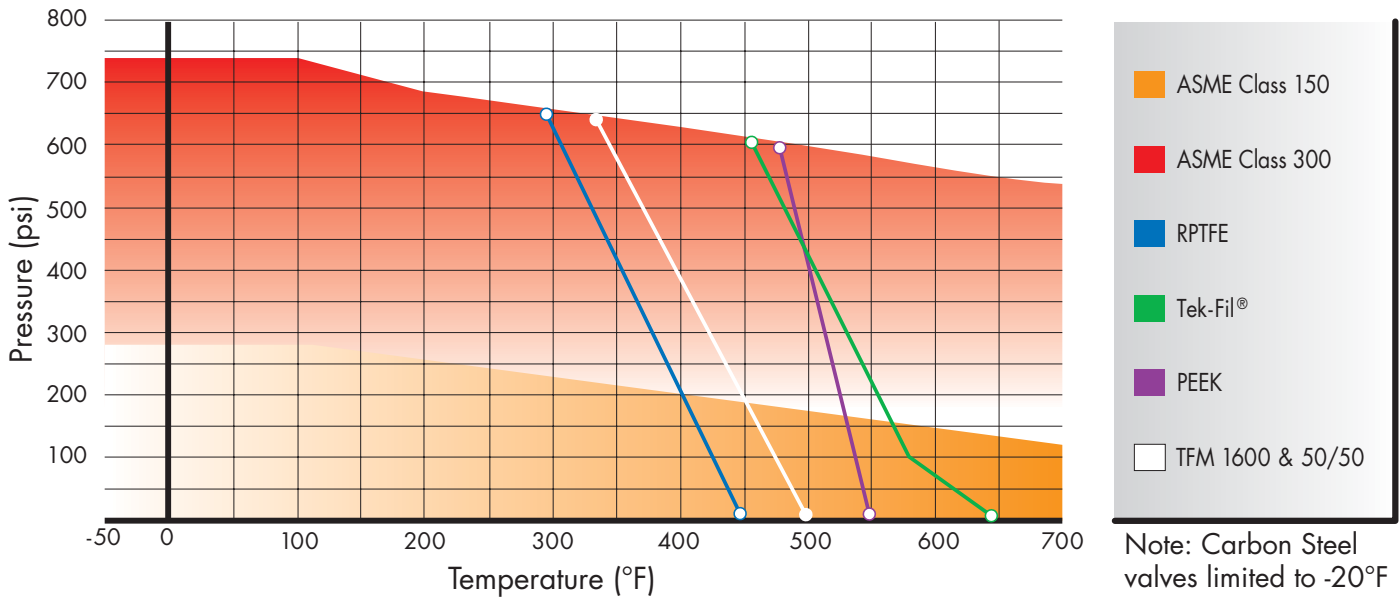

Carbon Steel valves limited to -20°F

### STEAM SERVICE PRESSURE RATINGS: WSP

	TFM Seats		Tek-Fil Seats		PEEK Seats	
	PSI	°F	PSI	°F	PSI	°F
Class 150:	150	365	190	383	170	374
Class 300:	150	365	425	454	425	454

Vacuum Service to 29.9 inches Hg. gauge.

### SEAT SELECTION

A wide range of seat materials are available to meet most applications. The standard seat is TFM 1600. Options include:

- RPTFE
- Stainless Steel/PTFE (50/50)
- UHMWPE
- Virgin PTFE
- PEEK
- Tek-Fil® (carbon/graphite filled TFM)
- Full Metal Seats
- Cavity Fillers

PEEK seats offer high pressure/temperature capability. Tek-Fil® seats offer reduced torque in high temperature, high cycle, and steam service applications. TFM 1600 seats offer the exceptional chemical resistance of PTFE plus lower porosity and permeability, improved temperature range and reduced valve torques.

### STANDARDS & CERTIFICATIONS

VALVE DESIGN	ASME B 16.34
	API 608
	MSS SP72
	NACE MRO175 all internal wetted parts
END FLANGES	ASME B 16.5
FACE TO FACE	ASME B 16.10 short pattern all sizes
ACTUATOR INTERFACE	ISO 5211
TESTING	API 598
	ASME B 16.34
	MSS SP 61
	API 607



# COMPONENTS & MATERIALS

ITEM / NAME	STAINLESS STEEL	CARBON STEEL	QTY.
1. Body	ASTM A351 Gr CF8M	ASTM A216 Gr WCB	1
2. End Cap	ASTM A351 Gr CF8M	ASTM A216 Gr WCB	1
3. Ball	ASTM A351 Gr CF8M		1
4. Seat	TFM 1600		2
5. Stem	ASTM A479 Gr 316		1
6. Body Seal	RPTFE		1
7. Anti-Static Device (not shown)	SS316		2
8. Packing Protector	PEEK		1
9. Thrust Washer Protector	PEEK		1
10. Thrust Washer	TEK-FIL		1
11. Stem Bearing	15% RPTFE		1
12. Stem Packing*	RPTFE/Graphite		3/1
13. Packing Gland Sleeve	SS304	Carbon Steel <sup>1</sup>	1
14. Packing Gland Plate	ASTM A351 Gr CF8	ASTM A216 Gr WCB	1
15. Gland Bolt	SS304	Carbon Steel	2
16. Belleville Washer	SS301		2
17. Tab Washer	SS304		1
18. Travel Stop Housing	ASTM A351 Gr CF8M	ASTM A216 Gr WCB	1
19. Housing Bolt	SS304	Carbon Steel	4
20. Travel Stop	SS304	Zinc Plated Carbon Steel	1
21. Travel Stop Set Sleeve	SS304		1
22. Travel Stop Bolt	SS304		1
23. Handle	SS304/Ductile Iron**		1
24. Lock Nut	SS304		2
25. Handle Bolt	Carbon Steel		1
26. Handle Sleeve (up to 2")	Vinyl		1
27. Locking Device	SS304		1
28. Snap Ring	Nickel Plated Carbon Steel		2

\*Quantity depends on valve size.

\*\* 3" and larger valves.

Flow-Tek offers the seat, body seal, thrust washer and stem packing as recommended spare parts. These parts are available as a packaged repair kit.

## 1" – 2" VALVES

Carbon Steel bodies on valve sizes 1" – 4" are Black Phosphate Coated.

All Stainless Steel bodies are solution annealed/normalized.

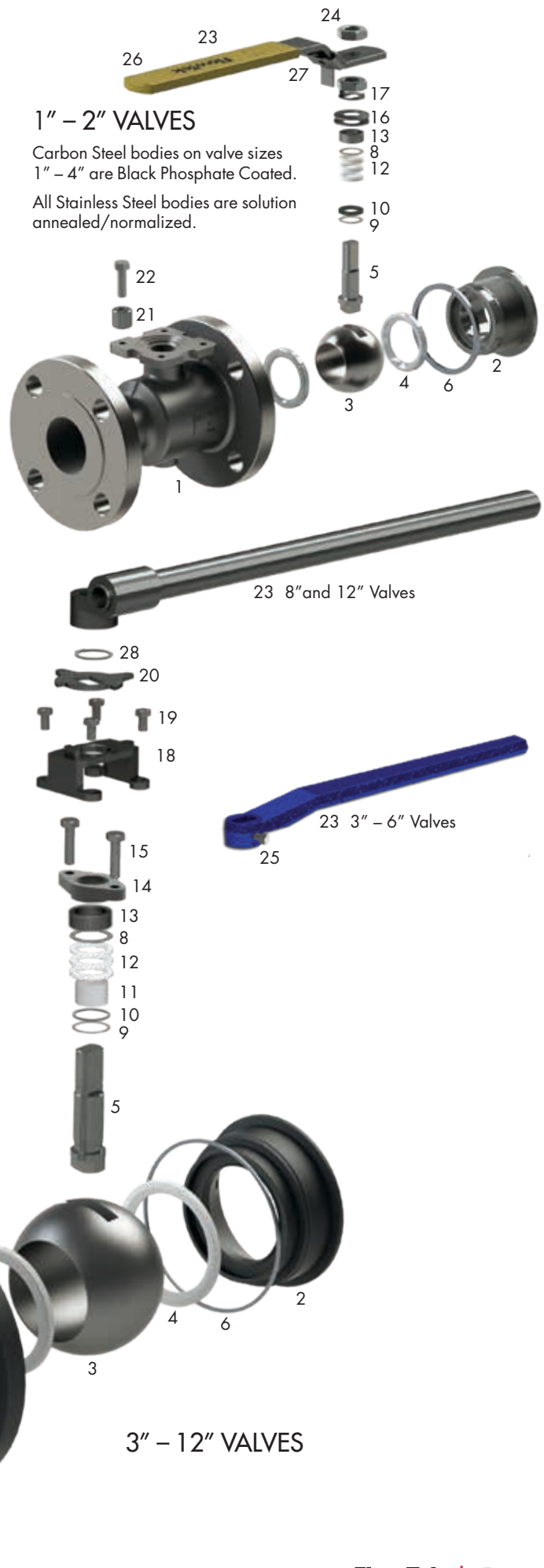

# RF15/RF30 GENERAL DIMENSIONS

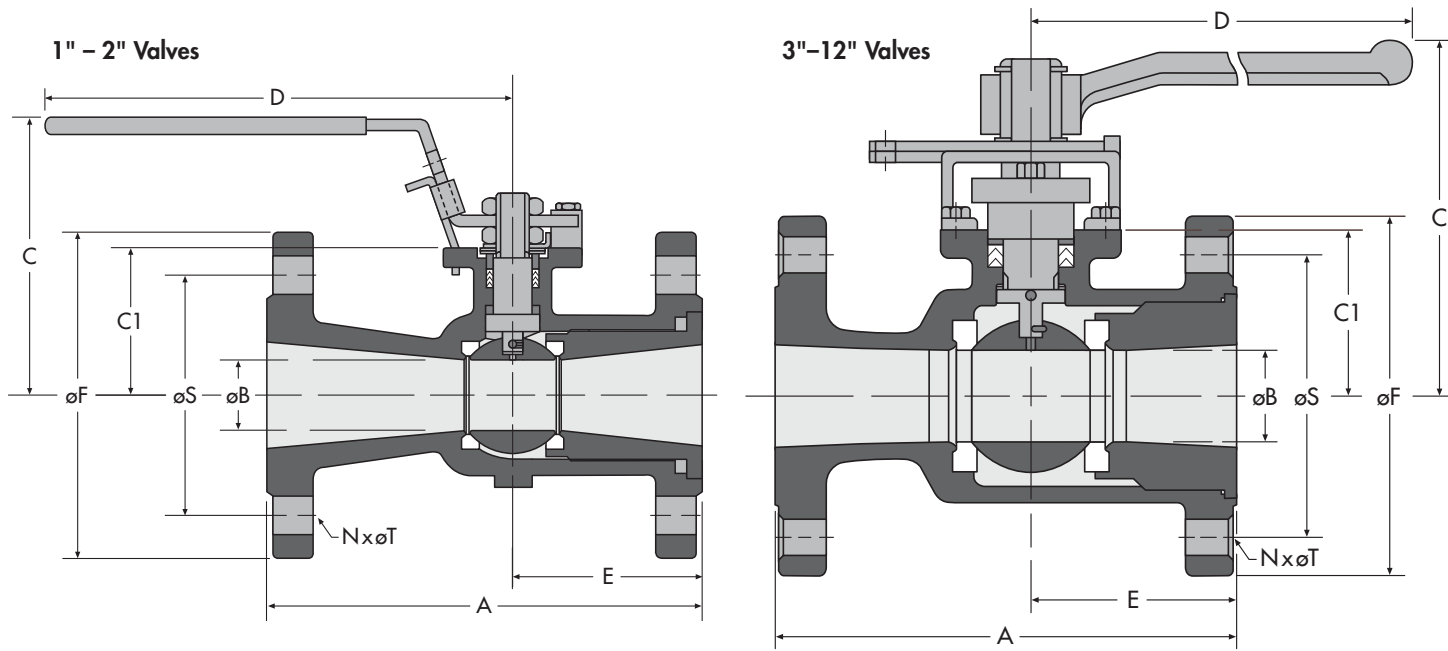

**NOTE:** Gear Operators are suggested on size 10" and 12" valves.  
**NOTE:** A trunnion-like Ball Support is included on size 12" valves.

### DIMENSIONS – Model RF15 – Class 150

	Size	A	øB	C	C1	D	E	øF	N	øS	øT	C <sub>v</sub>	Torque*	Approximate Weight
INCHES	1	5.00	0.79	2.91	1.67	6.50	2.00	4.25	4	3.12	0.63	32	65	6
	1½	6.50	1.26	3.62	2.20	7.87	2.17	5.00	4	3.88	0.63	82	155	11
	2	7.00	1.50	4.20	2.61	10.43	2.56	6.00	4	4.75	0.75	120	230	18
	3	8.00	2.56	5.98	3.09	15.35	3.27	7.50	4	6.00	0.75	350	500	39
	4	9.00	3.00	6.53	3.66	15.35	3.86	9.00	8	7.50	0.75	720	650	54
	6	10.50	4.00	7.20	4.33	15.35	4.61	11.00	8	9.50	0.87	1,020	1,505	90
	8	11.50	6.00	10.83	6.85	38.98	5.85	13.50	8	11.75	0.87	1,880	3,250	170
	10	13.00	7.87	11.61	7.62	38.98	6.85	16.00	12	14.25	1.00	4,000	4,750	350
	12	14.00	9.53	12.76	8.92	38.98	7.00	19.00	12	17.00	1.00	7,700	13,700	550
MILLIMETERS	25	127	20	74	42	165	51	108	4	79	16	32	7	3
	40	165	32	92	56	200	55	127	4	99	16	82	17	5
	50	178	38	107	66	265	65	152	4	121	19	120	26	8
	80	203	65	152	78	390	83	191	4	152	19	350	58	18
	100	229	76	166	93	390	98	229	8	191	19	720	74	25
	150	267	102	183	110	390	117	279	8	241	22	1,020	173	41
	200	292	152	275	174	990	149	343	8	298	22	1,880	374	77
	250	330	200	295	194	990	174	406	12	362	25	4,000	547	159
	300	356	242	324	227	990	178	483	12	432	25	7,700	1,578	250

Face to Face dimensions meet ASME B16.10 short pattern. \*Torque at maximum rated pressure, clean water, TFM 1600 seating material. Other seat materials exhibit different torques. Please refer to TB 1005 for specific torques.

**DIMENSIONS – Model RF30 – Class 300**

	Size	A	øB	C	C1	D	E	øF	N	øS	øT	Cv	Torque	Approximate Weight
INCHES	1	6.50	0.79	2.98	1.67	6.34	2.18	4.88	4	3.50	0.75	32	70	8.5
	1-1/2	7.50	1.25	3.65	2.20	7.72	2.60	6.14	4	4.51	0.87	82	175	17
	2	8.50	1.50	4.17	2.61	9.69	2.92	6.50	8	5.00	0.75	120	270	24
	3	11.12	2.50	5.98	3.00	15.35	3.75	8.28	8	6.62	0.87	350	600	55
	4	12.00	3.00	6.53	3.66	15.35	3.86	10.00	8	7.88	0.87	720	850	74
	6	15.88	4.00	7.21	4.33	15.35	4.61	12.52	12	10.62	0.87	1,020	2,600	132
	8	16.50	6.00	11.22	6.85	38.98	5.85	15.00	12	13.00	1.00	1,880	5,300	300
	10	18.00	8.00	12.72	7.62	38.98	6.85	17.50	16	15.25	1.13	4,000	7,600	460
	12	19.75	9.53	13.70	8.92	38.98	7.00	20.50	16	17.75	1.25	7,700	17,800	800
MILLIMETERS	25	165	20	76	42	161	55	124	4	89	19	32	8	4
	40	190	32	93	56	196	66	156	4	115	22	82	20	8
	50	216	38	106	66	246	74	165	8	127	19	120	31	11
	80	283	64	152	76	390	95	210	8	168	22	350	69	25
	100	305	76	166	93	390	98	254	8	200	22	720	97	34
	150	403	102	183	110	390	117	318	12	270	22	1,020	299	60
	200	419	152	285	174	990	149	381	12	330	25	1,880	610	136
	250	457	203	323	194	990	174	445	16	387	29	4,000	875	209
	300	502	242	348	227	990	178	521	16	451	32	7,700	2,050	363

Face to Face dimensions meet ASME B16.10 short pattern. \*Torque at maximum rated pressure, clean water, TFM 1600 seating material. Other seat materials exhibit different torques. Please refer to TB 1005 for specific torques.

**RF15/RF30 ACTUATOR MOUNTING PAD DIMENSIONS**

**1" – 2" Valves**

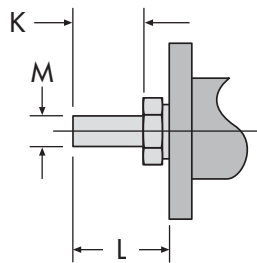
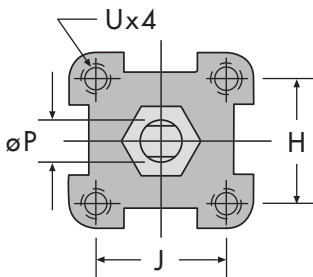

**3" – 12" Valves**

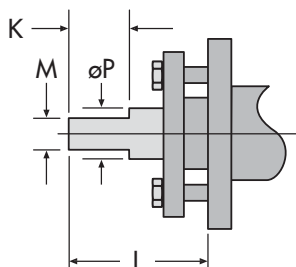
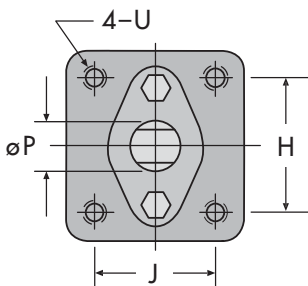

**DIMENSIONS – Secure Mount**

	Size	H	J	F0	BC DIA.	K	L	M	øP	U UNC
INCHES	1	1.17	1.17	F04	1.65	0.31	0.55	0.25	0.37	#10-24
	1-1/2	1.39	1.39	F05	1.97	0.43	0.75	0.31	0.43	1/4-20
	2	1.95	1.95	F07	2.76	0.47	0.91	0.37	0.62	5/16-18
	3-4 <sup>1</sup>	3.54	1.87	—	—	1.75	2.97 <sup>1</sup>	0.67	1.10	1/2-13
	6	3.54	1.87	—	—	1.75	3.07	0.67	1.71	1/2-13
	8	3.37	3.37	—	4.77	1.61	3.42	1.02	1.71	1/2-13
	10	3.37	3.37	—	4.77	2.13	3.86	1.02	1.71	1/2-13
MILLIMETERS	12	4.53	4.53	—	6.40	2.16	3.74	1.38	1.97	5/8-11
	25	30	30	F04	42	8	14	6	9	#10-24
	40	35	35	F05	50	11	19	8	11	1/4-20
	50	50	50	F07	70	12	23	9	16	5/16-18
	80-100 <sup>1</sup>	90	47	—	—	44	75 <sup>1</sup>	17	28	1/2-13
	150	90	47	—	—	44	78	17	43	1/2-13
	200	86	86	—	121	41	87	26	43	1/2-13
	250	86	86	—	121	54	98	26	43	1/2-13
300	115	115	—	163	55	95	35	50	5/8-11	

<sup>1</sup> For 4": L=3.07 (78 mm)



BRAY FLOW CONTROL SOLUTIONS ARE AVAILABLE FOR A VARIETY OF INDUSTRIES.

**ENERGY**

- Mining
- Oil & Gas
- Power / FGD
- Nuclear Power

**WATER**

- Water / Wastewater
- Ultra Pure Water
- Desalination
- Irrigation

**INDUSTRIAL**

- Chemical
- Pulp & Paper
- Textile
- Marine

**INFRASTRUCTURE**

- Beverage & Food
- Transportation
- Heating, Ventilation & Air Conditioning (HVAC)



DMC Gas Equipment Limited

(+852) 2851 2121

dmcsaleshk@dmc-gas.com.hk

www.dmc-gas.com.hk



THE SMART CHOICE FOR FLOW CONTROL SINCE 1986. WITH MORE THAN 300 LOCATIONS WORLDWIDE, FIND A REPRESENTATIVE NEAR YOU AT [BRAY.COM](http://BRAY.COM)



All statements, technical information, and recommendations in this bulletin are for general use only. Consult Bray representatives or factory for the specific requirements and material selection for your intended application. The right to change or modify product design or product without prior notice is reserved. Patents issued and applied for worldwide.